

OPERATION AND MAINTENANCE - MODEL 585 VISUAL INDICATOR - GMC # 44070 AND GMC # 44075

The visual indicator allows an operator to see a moisture indicating card in the high pressure line. The cards are seen through a high strength plastic window. The moisture card is divided into sections which progressively change color from blue to pink as moisture increases. Alternately other visual color changing indicators including a carbon monoxide indicator are available. Moisture indication tells when to change chemical drying cartridges. Normally cartridges should be changed when the indicator shows 40 to 60% relative humidity downstream of the dryer. Under high pressure, 60% relative humidity is still very dry air. For example, 3000 PSI air with a relative humidity of 60% has a dew point of -48° F .

The indicator cards are easily removed and changed from the front of the unit. No access to the back of the unit or disconnecting of lines is required. No tools are required. Pressure must be released before opening.

Indicator card, part number 592-5, shows relative humidities of 20, 40 and 60%. Indicator, part number 592-6, shows both relative humidity and dangerous levels of carbon monoxide in the air stream. However the carbon monoxide Indicator responds slowly over a period of several minutes so only provides an adequate warning for slowly changing conditions. Consequently it should be considered only a back-up to faster responding electronic instruments if sudden carbon monoxide build ups can occur. Consult the factory for further details. To install the element, unscrew the cap (2). The element (7 or 8) is then placed in the housing with the active side facing the window (3) to permit visual observation. When reinstalling the cap, insure the spring is in place to hold the element against the window. Tighten hand tight. No tools are necessary. See instructions with indicator elements for further details.

SPECIFICATIONS

*Maximum pressure rating	5000 PSI
*Inlet & outlet ports	1/4" female NPT - 180° apart
*Size	1 1/2"dia. x 2 1/4" with 1/2" dia view port
*Humidity indicator	shows when humidity is 20, 40, and 60 %
*Carbon monoxide indicator	shows when CO exceeds about 100 PPM
*Materials	body aluminum
	seals Viton
	window Lexan

TYPICAL APPLICATIONS

- *Humidity indicators in high pressure air lines Dryer / filter unit change indicators
- *High pressure compressors
- *High or low pressure air stations
- *High or low pressure process industry lines and systems
- *Instrument and high purity air lines

INSTALLATION Use a suitable pipe thread sealant on the inlet and outlet threads. Flow should be through the indicator. Do not install the indicator in a tee to one side of the main flow. This would increase the time it takes for the indicator to respond. The indicator can be installed in a panel by making a 1.5. or larger hole in the panel such that the window and removable cap can extend out from the panel while the piping connections can be located behind the panel. The indicator is sufficiently light so it can be supported by the piping connections. It can be installed with the window facing any direction.

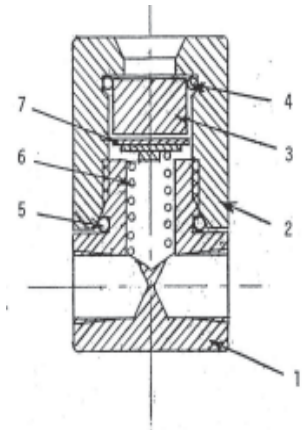

COLOR CHANGE - BLUE TO PINK MEANS HIGH HUMIDITY. TAN TO DARK BROWN MEANS DANGEROUS CARBON MONOXIDE

ASSEMBLY & DISASSEMBLY MODEL 585 VISUAL INDICATOR

ITEM	QTY	PART NO.	DESCRIPTION
1	1	583	body
2	1	584	cap
3	1	593	window
4	1	592-1	O ring 2-018
5	1	592-2	O ring 2-019
6	1	592-3	spring
7	1	592-5	Indicator 20/40/60 humidity
8	1	592-6	Indicator CO & humidity

NOTES

1. Technical bulletin -588
2. Use Dow silicone grease 111 or equivalent on seals and threads.
3. Tighten cap hand tight only
4. Install window (3) with smooth, small diameter against O-ring (4)
5. Insure window (3) is fully against shoulder of cap (2).
6. Avoid spring or other hard objects touching window
7. Keep elements sealed in aluminum foil packs until used.
8. When installing CO/Humidity elements peel backing tape off blue humidity strip, paste to front side (rough surface) of brown CO button and install in cap so both CO and humidity elements can be seen through window, insure spring is in place to hold element against window.
9. When installing humidity element place it in cap (2) with blue face against window.
10. Color change - blue to pink means high humidity, tan to dark brown means dangerous levels of carbon monoxide.

